

LGX 3U Chassis

Optronics offers an innovative, robust, high density 3U Chassis. This panel has been designed to accept up to 14 LGX style assemblies.

With the ability to use a full array of Adaptor types offering a flexible solution to the end user, enabling them to incorporate a multi functional chassis which allow easy access during installation or re-work with no disturbance of the existing cable or fibres.

In the addition to the array of adaptors the chassis also offers multiple cable entry solutions, MTP trunk cables connected to 14 individual MTP cassettes with up to 24 fibres in each, loose tube cable connecting to 14 Individual extended cassettes to allow standard splicing or 14 LGX modules for pre terminated solutions, making this chassis one of the most flexible on the market.

Features/Benefits

- > Up to 14 LGX components.
- > Up to 14 x 24 fibre MTP cassettes.
- > Multiple adaptor options available
- > Fully integrated fibre management.
- > Splicing option available.
- > Flat pack for easy shipment.
- > Patch cord exit retrofit cable management available.
- > 30mm bend radius maintained throughout.
- > Individually labelled ports.
- > Accepts loose tube, distribution cable and MTP trunk cable.
- > ROHS, REACH SvHC and UL rated.
- > Fits standard 19".
- > Rear cable management bar as standard.

Applications

- > Data centres, premise installations, telecommunication networks.
- > Ethernet, Fibre Channel, ATM, LAN, MAN and WAN
- > Data communication.
- > Indoor applications.

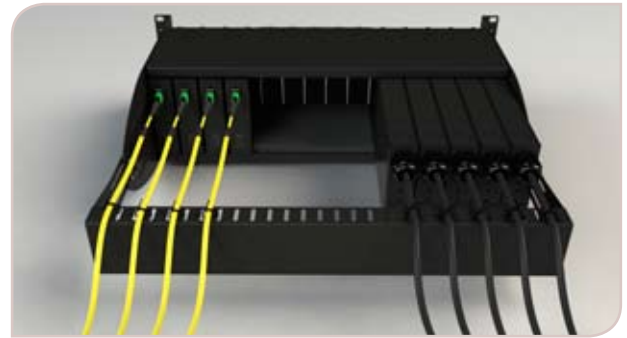
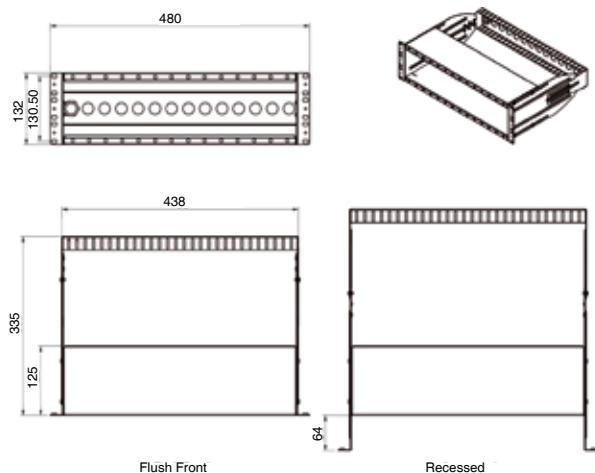

Product Specification

| | |
|-----------------------------|--|
| U Size | 3U (133.2mm) |
| Width | 480mm |
| Depth | 335mm |
| Net weight | 2.76 kgs |
| Packaged weight | 3.24 kgs |
| Packaged dimensions | 490mm W x 110mm H X 240mm D |
| IP rating | N/A |
| Suitable for Adaptor type | LGX / MTP Cassettes |
| Number of Module Positions | 14 |
| Mounting Adjustment range | 64mm |
| Material | Cold- rolled steel |
| Material thickness | 1.5mm |
| Material coating | Powder coating |
| Colour | RAL 9004 / RAL 7035 |
| Operating temperature | -40°C to +50°C |
| Designed in accordance with | TIA/EIA 568.C, ISO/IEC 11801, EN50173, IEC60304, IEC61754, EN297-1 |
| Compliant to | RoHS, Reach/SVHC |